

Stationary, digital pyrometers for non contact temperature measurement between 250°C and 3000°C

impac® IS 5 • IGA 5
Infrared thermometry



- Temperature ranges between 250 and 3000°C
- Very small spot sizes, min. 0.5 mm
- Different sightings available: laser targeting light, thru-lens view finder or video module
- Analog output adjustable
0 - 20 mA or 4 - 20 mA
- Built-in maximum value storage
- Digital interface
- Bus capable with RS485 interface
- Small dimensions



The pyrometers **IS 5** and **IGA 5** are digital, compact and fast infrared measuring instruments for non-contact temperature measurement on metals, ceramics or graphite.

For optimal match of the instrument to the application 2 different optics with extremely small spot sizes are available.

The response time of only 2 ms facilitates the measurement of fast heating processes or short temperature peaks.

For a precise alignment of the pyrometers to the measuring object, the instruments are optionally equipped with a laser targeting light, a view finder or a video module.

The most important parameters as emissivity, exposure time and analog output can be set directly in the instrument.

Additionally the pyrometer can be connected to a PC via serial interface, enabling adjustments of further parameters with the delivered

software *InfraWin*. This can be used for temperature indication, data logging and further analyzing of complete temperature processes.

Typical applications:

- Induction heating
- Casting
- Annealing
- Welding
- Forging
- Sintering
- Melting
- Rolling
- Hardening

Technical data

	IS 5	IGA 5
Temperature range:	600 to 2000°C (MB 20) 800 to 2500°C (MB 25) 1000 to 3000°C (MB 30)	350 to 1800°C (MB 18) 250 to 2000°C (MB 20) 400 to 2500°C (MB 25) 500 to 3000°C (MB 30)
Sub range:	User adjustable (minimum span is 51°C)	
IR detector:	Silicon photo diode (Si)	Indium-Gallium-Arsenic photo diode (InGaAs)
Spectral range:	0.8 to 1.1 µm	1.45 to 1.8 µm
Power supply:	24 V DC ± 25%, stabilized, ripple must be less than 50 mV	
Power consumption:	≤ 3 W (incl. active laser targeting light)	
Analog output:	0 - 20 mA or 4 - 20 mA, switchable, linear in temperature, load independent DC	
Interface:	Optional RS232 or RS485 (addressable), half duplex, baud rate 1.2 up to 38.4 kBd	
Resolution:	0.1°C at the interface at the analog output < 0.1% of the adjusted temperature range but min. 0.1°C	
Isolation:	Power supply and digital output and analog output are galvanically isolated against each other	
Parameters:	Adjustable on the converter's rear side: emissivity, response time, analog output 0 - 20 mA or 4 - 20 mA, online / offline mode for settings via PC or pyrometer. Additionally via interface adjustable and readable: temperature sub range, settings for maximum value storage, address, baud rate. Via interface readable only: measured value, internal temperature of the unit Pyrometers with PID-controller via software adjustable: set point, proportional band, rate time / integral time, output delimitation.	
Maximum value storage:	Single or double storage, clear modes: time (off; 0.01 s; 0.05 s; 0.25 s; 1 s; 5 s; 25 s), external clear contact, via interface or automatic „hot object mode“, hold-function for freezing the current temperature reading (not at pyrometers with PID-controller)	
Emissivity ε:	0.2 to 1 adjustable in the instrument or with the software <i>InfraWin</i> in steps of 0.01	
Response time t ₉₀ :	≤ 2 ms, adjustable to 0.01 s; 0.05 s; 0.25 s; 1 s; 3 s; 10 s	
Measurement uncertainty: (T _{amb.} = 25°C, ε = 1, t ₉₀ = 1 s)	< 350°C: 0.5% of reading in °C + 1°C 350 to 1500°C: 0.3% of reading in °C + 1°C > 1500°C: 0.5% of reading in °C + 1°C	
Repeatability:	0.2% of reading in °C + 1°C (T _{amb.} = 25°C, ε = 1, t ₉₀ = 1 s)	
Noise equivalent temperature difference (NETD):	0.4°C (t ₉₀ = min=2 ms); 0.1°C (t ₉₀ = 0.01 s) (ε = 1, T _{amb.} = 10 to 40°C)	
Sighting system:	Laser targeting (max. power level < 1 mW, λ = 630-680 nm, CDRH class II) or thru-lens view finder or video module	
Protection class:	IP65 (DIN 40050)	
Ambient temperature:	0 to 70°C	
Storage temperature:	-20 to 70°C	
Weight:	550 g	
Housing:	Stainless steel, dimension see drawing on the right side	
CE-label:	According to EU directives about electromagnetic immunity	



Additional technical data for pyrometers with built-in video module:

Video signal:	CCIR norm approx. 1 V _{pp} at 75 Ω, 50 Hz (special option: EIA norm 60 Hz, NTSC-M compatible)
Array size:	CCIR norm: 628 x 583 pixels, black & white (EIA norm: 510 x 492 pixels, black & white)
Exposure:	Automatic, additionally 3-levels controlled by the measuring temperature
Field of view:	Approx. 10% x 14% of focused distance
Date/time:	Real-time clock with at least 3 days spare run
Video output plug:	Separate round plug at the pyrometer, not galvanically separated to the pyrometers power supply
Picture insertions:	Target marking; unit number or user text (max. 12 characters), time and/or date; (individually switchable), measuring temperature, emissivity

Sighting

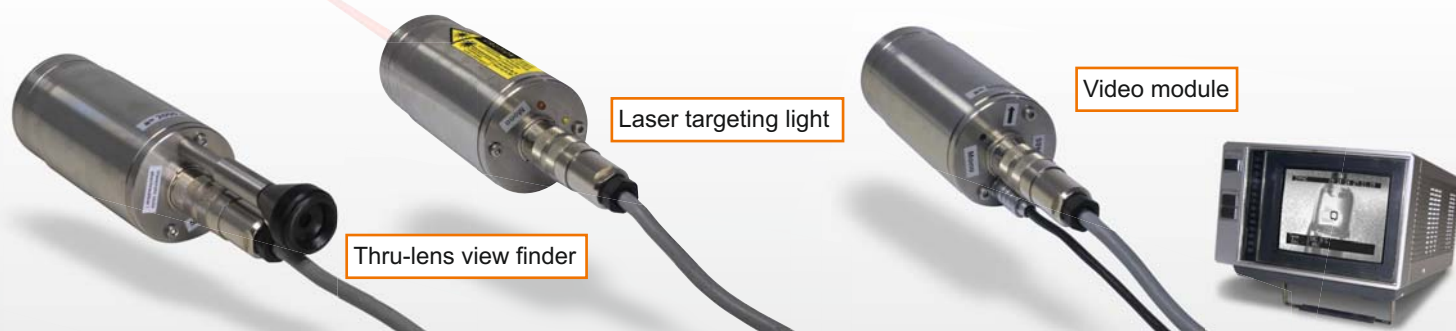

Optics

Two different optics are available. The optics are adjusted ex works to one of the distances “a” mentioned in the table below, to achieve the smallest possible spot size in the corresponding measuring distance (measured from the front of the housing). The required measuring distance has to be specified when ordering, other distances within the optics range are possible on request.

Optics F for long distances 220 ... ∞	Temperature range			
	IS 5		IGA 5	
	MB 20	MB 25 MB 30	MB 20	MB 18 MB 25 MB 30
Meas. distance a [mm]	Spot size M_{90} [mm]			
220 mm	2	1	2	1
300 mm	2.7	1.4	2.7	1.4
500 mm	4.8	2.4	4.8	2.4
800 mm	8	4	8	4
1300 mm	13	6.6	13	6.6
2000 mm	22	12	22	12
4000 mm	50	28	50	28
Aperture D [mm]	5	5 (MB 25) 3 (MB 30)	8	8 (MB 18, 25) 5 (MB 30)

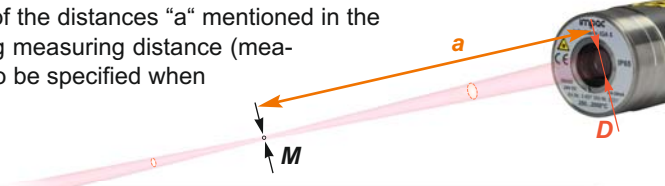

Optics N for short distances 90 ... 250 mm	Temperature range			
	IS 5		IGA 5	
	MB 20	MB 25 MB 30	MB 20	MB 18 MB 25 MB 30
Meas. distance a [mm]	Spot size M_{90} [mm]			
90 mm	1	0.5	1.1	0.7
100 mm	1.1	0.6	1.3	0.8
150 mm	1.8	0.9	2	1.1
200 mm	2.6	1.4	2.6	1.4
250 mm	3.1	1.6	3.6	1.8
Aperture D [mm]	5	5 (MB 25) 3 (MB 30)	8	8 (MB 18, 25) 5 (MB 30)

Dimensions

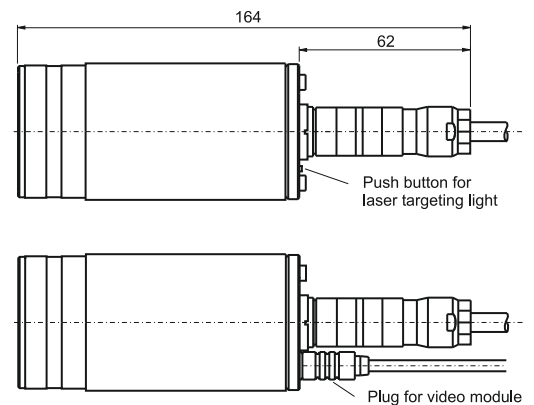
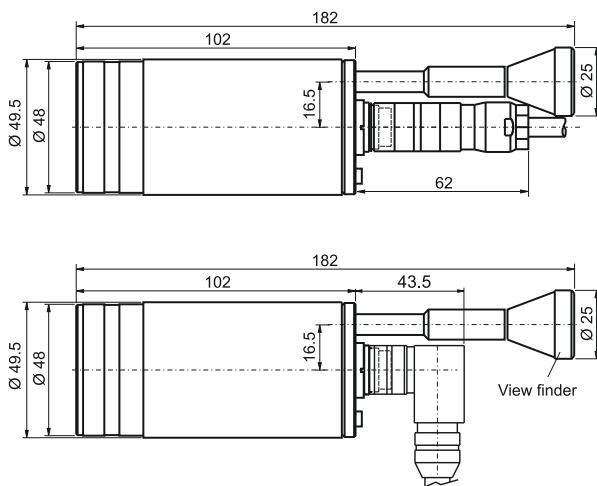

All dimensions in mm

Instrument settings

Offline mode: the most important parameters as emissivity, exposure time and analog output can be set directly in the instrument. After removing the cover on the back side of the pyrometer, the corresponding adjustments are accessible.

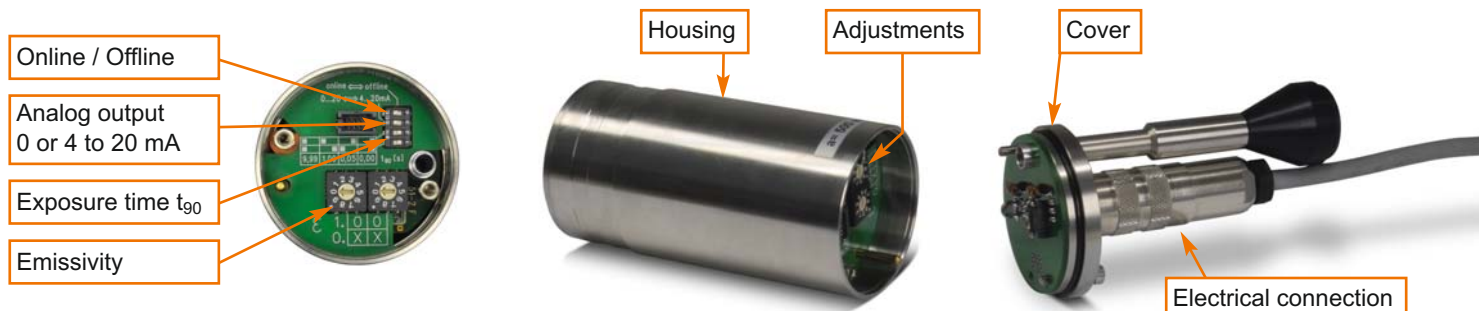

Online mode: switch to online mode to enable the communication via serial interface and software *InfraWin* (in scope of delivery) on a PC.

This allows additional setting options as well as the graphical temperature display combined with subsequent analysis of the measurement values.

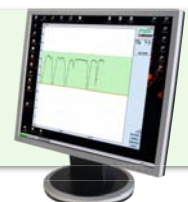

Reference numbers

Type	Temperature range	With laser targeting light		With thru-lens view finder		With video module *)	
		Interface		Interface		Interface	
		RS232	RS485	RS232	RS485	RS232	RS485
IS 5	MB 20: 600 to 2000°C	3 857 150	3 857 160	3 857 170	3 857 180	3 847 150	3 847 160
	MB 25: 800 to 2500°C	3 857 200	3 857 210	3 857 220	3 857 230	3 847 200	3 847 210
	MB 30: 1000 to 3000°C	3 857 250	3 857 260	3 857 270	3 857 280	3 847 250	3 847 260
IGA 5	MB 18: 350 to 1800°C	3 857 400	3 857 410	3 857 420	3 857 430	3 847 400	3 847 410
	MB 20: 250 to 2000°C	3 857 350	3 857 360	3 857 370	3 857 380	3 847 350	3 847 360
	MB 25: 400 to 2500°C	3 857 450	3 857 460	3 857 470	3 857 480	3 847 450	3 847 460
	MB 30: 500 to 3000°C	3 857 920	3 857 930	3 857 940	3 857 950	3 847 920	3 847 930

*) Standard in CCIR norm. Video module with EIA norm please order separately.

Scope of delivery: Converter, works certificate, PC operating and analyzing software *InfraWin*.

Ordering details: - When ordering please select optics N or F as well as the required measuring distance.
- A connection cable or video cable is not included in scope of delivery, it has to be ordered separately.

Accessories:

3 820 330	connection cable, 5 m, straight connector	3 837 230	Water cooling jacket (heavy design) with integrated air purge unit
3 820 500	connection cable, 10 m, straight connector	3 837 370	Water cooling jacket (lightweight design, only pyrometers with laser targeting light) with integrated air purge unit
3 820 510	connection cable, 15 m, straight connector	3 846 590	Vacuum flange KF16 with quartz glass window
3 820 810	connection cable, 20 m, straight connector	3 852 290	Power supply NG DC for DIN rail mounting; 100 to 240 V AC ⇒ 24 V DC, 1 A
3 820 820	connection cable, 25 m, straight connector	3 852 550	Power supply NG 2D (85...265 V AC ⇒ 24 V DC, 600 mA, with 2 limit switches)
3 820 520	connection cable, 30 m, straight connector	3 890 640	DA 4000-N: LED digital display (switchboard assembling)
3 820 740	connection cable, 5 m, straight connector, temperature resistant up to 200°C	3 890 650	DA 4000: as DA 4000-N, additionally with 2 limit switches
3 821 050	connection cable, 5 m, 90° connector	3 890 560	DA 6000-N: LED digital display with digital input RS232 and possibility for setting pyrometer parameters
3 821 060	connection cable, 10 m, 90° connector	3 890 570	DA 6000-N with RS485
3 821 330	connection cable, 12 m, 90° connector	3 890 520	DA 6000: LED digital display, digital- and analog input, 2 limit switches, maximum value storage, analog output, RS232
3 821 280	connection cable, 20 m, 90° connector	3 890 530	DA 6000 with RS485
3 820 430	Video cable with Cinch-/SCART plug 5 m (other length up to 30 m available)	3 826 500	HT 6000: portable battery driven indicator and instrument for pyrometer parameter settings; RS232 / RS485
3 821 220	Video cable with BNC plug 5 m (other length up to 20 m available)	3 826 510	PI 6000: programmable PID controller
3 834 210	Adjustable mounting support		
3 835 160	Air purge unit, aluminium		
3 835 440	Air purge unit, stainless steel		

Overview accessories

Mechanical:

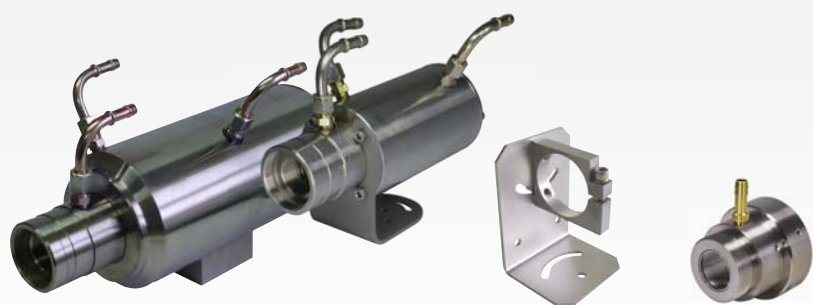

Water cooling jackets (heavy and lightweight design)

Adjustable mounting support

Air purge unit, stainless steel

Electrical:



LED digital display DA 6000

Power supplies NG DC NG 2D

LumaSense Technologies

Americas and Australia

Sales & Service
Santa Clara, CA
Oakland, NJ

Tel.: +1 800 631 0176

Fax: +1 408 727 1677

info@lumasenseinc.com

Europe, Middle East, Africa

Sales & Service
D-60326 Frankfurt, Germany
Kleyerstr. 90

Tel.: +49 69 97373-0

Fax: +49 69 97373-167

India

Sales & Support Center
Mumbai, India

Tel.: +91 22 67419203

Fax: +91 22 67419201

China

Sales & Support Center
Shanghai, China

Tel.: +86 21 5882 2277

Fax: +86 21 5887 0077

Visit lumasenseinc.com for local sales representation