

- Measure
- Monitor
- Control

impac[®]

A LUMASENSE TECHNOLOGIES Company



IP 140 · IPE 140

Highly accurate, fully digital, fast

Pyrometer with focusable optics for non-contact temperature measurements on metals, ceramics, graphite etc. between 5 and 1300°C

- ◆ Short response times, min. 1.5 ms
- ◆ Extremely small spot sizes, min 0.3 mm
- ◆ Built-in digital display with temperature indication
- ◆ Parameter adjustments via integrated key pad or interface
- ◆ Optimized thru-lens view finder or laser targeting light
- ◆ Test current output
- ◆ Housing with precision mounting rail for safe mounting and accurate alignment
- ◆ Interface RS232 / RS485 switchable
- ◆ Focusable optics



The **IP 140** and **IPE 140** are digital, highly accurate pyrometers for non-contact temperature measurement on metals, ceramics, graphite etc. For optimal match of the instrument to the application different focusable optics with extremely small spot sizes are available. The pyrometer parameters can be selected via the integrated key pad, the settings are indicated on the built-in LC-Display. In measuring mode the actual temperature is indicated.

The pyrometers are equipped with RS232 and RS485 serial interfaces (switchable inside the pyrometer). This enables additionally the reading of temperature and pyrometer parameters via the provided *InfraWin* PC-software. If necessary the parameters also can be changed via PC.

A laser targeting light or thru-lens view finder for exact alignment of the pyrometer is available.

Typical applications:

- preheating
- annealing
- tempering
- welding
- forging
- hardening
- sintering
- melting
- soldering
- rolling
- brazing
- normalizing

Technical Data

	IP 140	IPE 140
Temperature ranges:	50 ... 400°C (MB 4) 75 ... 550°C (MB 5.5) 100 ... 700°C (MB 7) 160 ... 1200°C (MB 12) 200 ... 1300°C (MB 13)	5 ... 350°C (MB 3.5) 5 ... 500°C (MB 5) 30 ... 1000°C (MB 10) 50 ... 1200°C (MB 12)
Subrange:	any range adjustable within the temperature range, minimum span 51°C	
Spectral range:	2 ... 2.8 µm	3 ... 5 µm
Signal processing:	alternating light signal, digitized immediately	
Accuracy: ($\epsilon = 1$, $t_{90} = 1$ s, $T_{amb.} = 23^\circ\text{C}$)	below 400°C: 2°C above 400°C: 0,3% of reading in °C +1°C	MB 3.5: below 250°C: 1°C above 250°C: 0.4% of reading in °C +1°C All others: below 400°C: 2.5°C above 400°C: 0.4% of reading in °C +1°C
Repeatability:	0.1% of reading in °C + 1°C	MB 3.5: 0.1% of reading in °C + 0.2°C All others: 0.1% of reading in °C + 1°C
Resolution:	interface and display: 0.1°C, analog output: < 0.03% of temperature range	
Exposure time t_{90} :	1.5 ms, with dynamical adaption at low signal levels; adjustable up to 10 s	
Emissivity ϵ :	10 ... 100% adjustable in steps of 0.1%	
Analog output:	linear 0 ... 20 mA or 4 ... 20 mA, DC, switchable; load max. 500 Ohm	
Test current output:	fixed 10 mA (for 0 ... 20 mA analog output) or fixed 12 mA (for 4 ... 20 mA analog output)	
Power supply:	24 V AC/DC (14 ... 30 V AC/DC) (AC: 48 ... 62 Hz)	
Power consumption:	max. 6 VA	
Sighting:	laser targeting light or thru-lens view finder	
Serial interface:	switchable inside the pyrometer: RS232 or RS485 addressable, half duplex; baud rate up to 115 kBd	
Parameters:	adjustable at the instrument or via serial interface: emissivity; exposure time; analog output; address; baud rate; waiting period; °C or °F; setting of the maximum value storage; temperature sub range	
Maximum value storage:	single or double storage; cleared by: preselected time interval or external deletion contact or via digital interface or automatically with the next measuring object	
Isolation:	power supply, digital interface, analog output are galvanically isolated against each other and housing	
Protection class:	IP65 (DIN 40 050)	
Ambient temperature:	0 ... 53°C at housing	
Storage temperature:	-20 ... 60°C	
Weight:	approx. 550 g	
Dimensions [mm]:	195 x 56 x 62.5 (L x W x D)	
Mechanical tests:	vibration proof corresponding DIN EN 60068-2-6, shock proof corresponding DIN EN 60068-2-27	
Relative humidity	Non condensing conditions	
CE-label:	according to EU directives about electromagnetic immunity	

Advantages of the digital signal processing

The signal processing of series 140 pyrometers is fully digital, i.e. the detector signal are digitized immediately and digitally processed. With this technique an extremely high accuracy and repeatability as well as very long measuring ranges are achieved.

Accuracy: The high accuracy is achieved by the digital linearisation of the sensor output as well as the digital compensation of the ambient temperature.

Temperature range: Due to the digital technique the user can set any temperature sub range within the full temperature range. The minimum span of the sub range is 51°C. The analog measuring output corresponds automatically to the selected sub range. This setting of a sub range can be done without recalibration of the pyrometer and does not effect the high accuracy and repeatability. As almost any sub range is adjustable, the storage of spare instruments or the replacement of other pyrometers is simplified.

Output: The analog measuring outputs 0 ... 20 mA or 4 ... 20 mA are selectable as well as the serial digital interfaces RS232 or RS485. Additionally the interface allows the controlling of the pyrometer via PC.

Bus control: The serial interface RS485 facilitates the integration of the pyrometer into existing field bus systems.

Calibration: If a suitable calibration source is available, a calibration of the pyrometers can be done via serial interface without opening the housing.

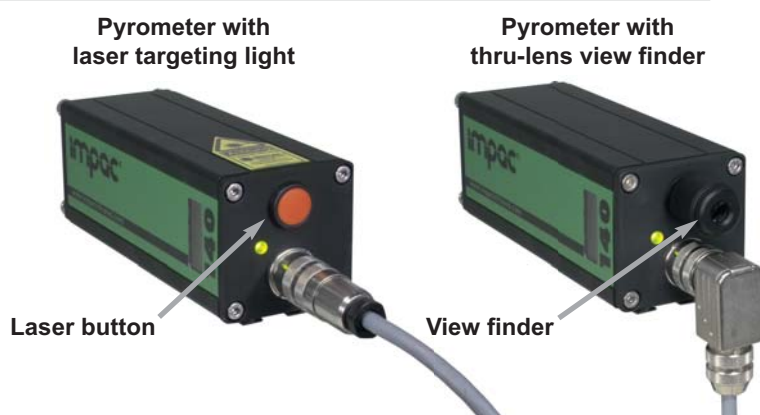

Optics

The pyrometers are available with different focusable optics. They offer the smallest possible spot size at any distance. The adjustment can be done easily without additional tools with help of the „turn and clamp“ mechanism (one hand). The spot sizes are shown in the following table (all distances are measured from the front of the lens). The different optics are exchangeable without recalibration of the pyrometer. For spot sizes between those in the table, values can be found by interpolation.

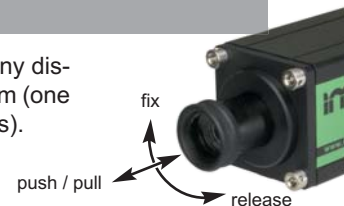

Focusable optics IP 140						
	Meas. distance a [mm]	Spot size M_{90} [mm]				
		MB 4	MB 5.5	MB 7	MB 12	MB 13
Optics 0-P	70	1.7	0.9	0.7	0.4	0.3
	78	2.0	0.9	0.7	0.4	0.3
	90	2.5	1.0	0.8	0.4	0.3
Optics 1-P	105	2.3	1.0	0.8	0.4	0.3
	120	2.8	1.2	1.0	0.5	0.4
	150	4.0	1.6	1.3	0.6	0.5
Optics 2-P	200	4.1	1.8	1.4	0.7	0.5
	260	5.6	2.4	1.8	0.8	0.7
	440	11.2	4.3	3.3	1.3	1.0
Optics 3-P	345	6.7	2.7	2.0	0.9	0.7
	1000	23	9	6.8	2.6	2.4
	4300	105	41	31	11	10
Aperture D [mm]:		14 ... 17		12 ... 14		8 ... 10

Focusable optics IPE 140					
	Meas. distance a [mm]	Spot size M_{90} [mm]			
		MB 3.5	MB 5	MB 10	MB 12
Optics 0-PE	71	2.4	1.6	-	-
	78	3.0	2.0	-	-
	90	3.6	2.4	-	-
Optics 1-PE	105	3.6	2.4	1.1	0.9
	120	4.4	2.9	1.3	1.0
	150	6.2	4.1	1.7	1.4
Optics 2-PE	200	6.3	4.2	1.8	1.4
	260	8.6	5.7	2.4	1.8
	440	17.1	11.4	4.6	3.5
Optics 3-PE	345	10.2	6.8	2.9	2.3
	1000	34.5	23	9.2	7.1
	4300	158	105	42	32
Aperture D [mm]:		14 ... 17			

Reference numbers

IP 140	With laser targeting light	With thru-lens view finder
MB 4: 50 ... 400°C	3 875 500	3 875 510
MB 5.5: 75 ... 550°C	3 875 520	3 875 530
MB 7: 100 ... 700°C	3 875 540	3 875 550
MB 12: 160 ... 1200°C	3 875 560	3 875 570
MB 13: 200 ... 1300°C	3 875 580	3 875 590

IPE 140	With laser targeting light	With thru-lens view finder
MB 3.5: 5 ... 350°C	3 875 900	-
MB 5: 5 ... 500°C	3 875 740	3 875 750
MB 10: 30 ... 1000°C	3 875 720	3 875 730
MB 12: 50 ... 1200°C	3 875 700	3 875 710

Ordering note:

When ordering please select one focusable optics. A connection cable is not included in scope of delivery.

Ordering example:

3 875 570 IP 140 with thru-lens view finder, focusable optics 2-P, temperature range 160 ... 1200°C
 3 820 530 connection cable, length 10 m, with 90° connector

Scope of delivery: Pyrometer with focusable optics, works certificate, *InfraWin* operating and analyzing software



Accessories:

3 820 340	connection cable, length 5 m, 90° connector	3 837 240	cooling plate
3 820 530	connection cable, length 10 m, 90° connector	3 835 450	90° mirror for IP 140
3 820 540	connection cable, length 15 m, 90° connector	3 835 460	90° mirror for IPE 140
3 820 830	connection cable, length 20 m, 90° connector	3 843 520	rugged scanner SCA 140, (scanning angle adjustable 0 ... 12°, scanning frequency adjustable 1 ... 5 Hz), with quartz glass window for IP 140
3 820 840	connection cable, length 25 m, 90° connector		
3 820 550	connection cable, length 30 m, 90° connector		
3 820 330	connection cable, length 5 m, straight connector	3 843 530	rugged scanner SCA 140, with CaF ₂ window for IPE 140
3 820 500	connection cable, length 10 m, straight connector		
3 820 510	connection cable, length 15 m, straight connector	3 835 290	air purge for scanner SCA 140
3 820 810	connection cable, length 20 m, straight connector	3 852 540	power supply NG 0D for DIN rail mounting; 85 ... 265 V AC ⇒ 24 V DC, 600 mA
3 820 820	connection cable, length 25 m, straight connector		
3 820 520	connection cable, length 30 m, straight connector	3 852 550	power supply NG 2D, as NG 0D: additionally with 2 limit switches
3 820 740	connection cable, length 5 m, straight connector, temperature resistant up to 200°C		
		3 890 640	LED digital display DA 4000-N
3 820 750	connection cable, length 5 m, 90° connector, temperature resistant up to 200°C	3 890 650	LED digital display DA 4000: with 2 limit switches
		3 890 560	LED digital display DA 6000-N: with possibility for pyrometer parameter settings for digital <i>INFRA THERM</i> pyrometers; RS232 interface
3 834 280	adjustable mounting angle		
3 834 270	ball and socket mounting		
3 835 230	air purge	3 890 520	LED digital display DA 6000; DA 6000-N additional with 2 limit switches and analog input and output
3 837 290	cooling jacket, stainless steel		
3 835 060	air purge for cooling jacket	3 826 500	HT 6000, portable battery driven indicator and instrument for pyrometer parameter setting
3 834 200	ball and socket mounting for cooling jacket		

Dimensions

Pyrometer with thru-lens view finder

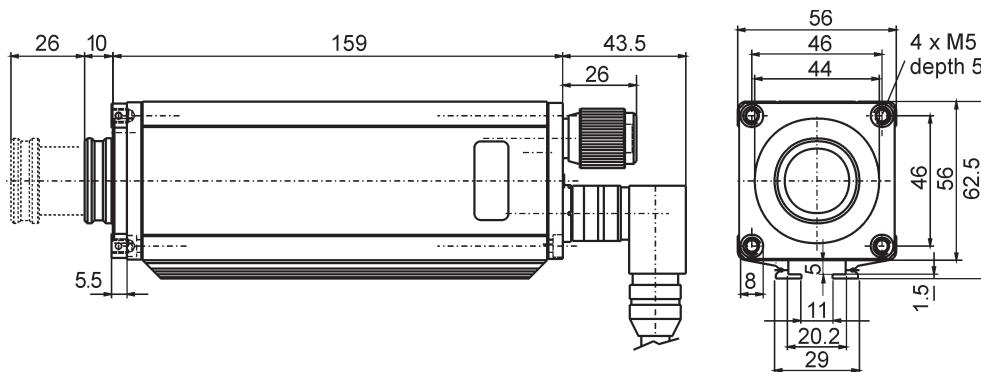

Pyrometer with laser targeting light

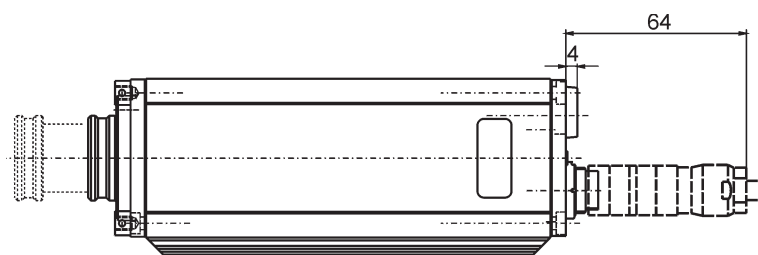

All dimensions in mm

Overview Accessories



Ball and socket mounting

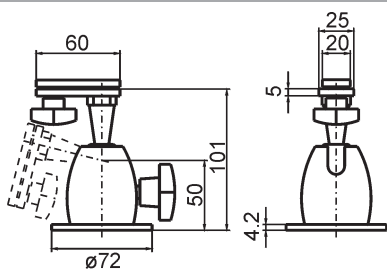

Mounting angle

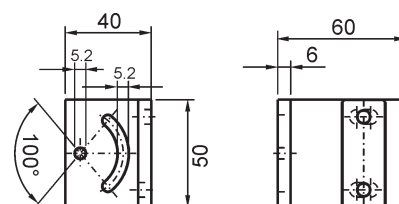

Cooling plate



90° mirror



air purge



Pyrometer with emissivity enhancer

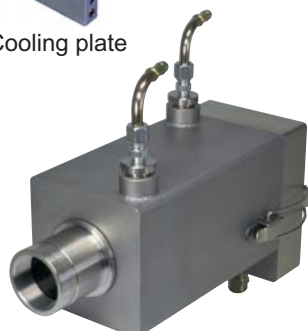

Stainless steel cooling jacket



Scanner SCA 140 for small angles up to 12°



LED digital display



cooling jacket with emissivity enhancer

IMPAC Infrared GmbH
Temperature Measurement

Kleyerstr. 90
D-60326 Frankfurt/Main

Phone: +49(0)69-9 73 73-0
Fax: +49(0)69-9 73 73-167

E-Mail: info@impacinfrared.com
Internet: www.impacinfrared.com



Specifications are subject to change without notice